

1) BOTTOM PLANK

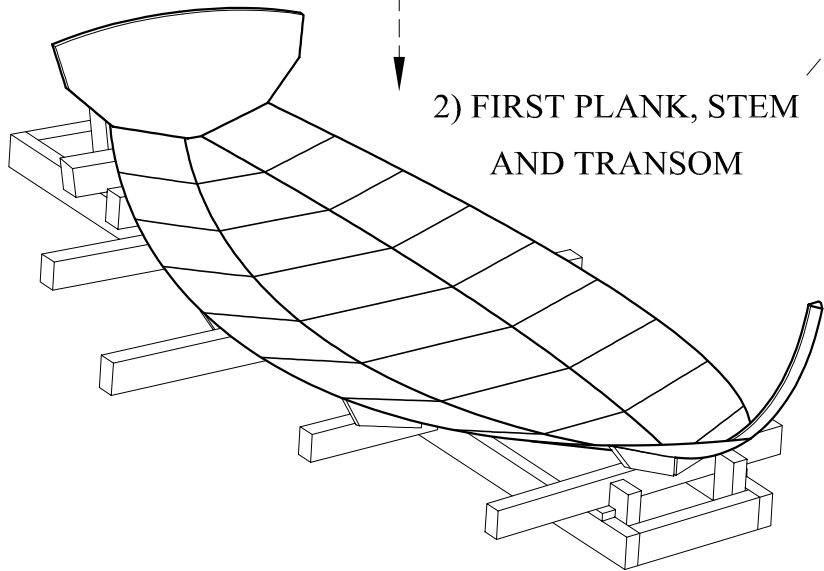

2) FIRST PLANK, STEM AND TRANSOM

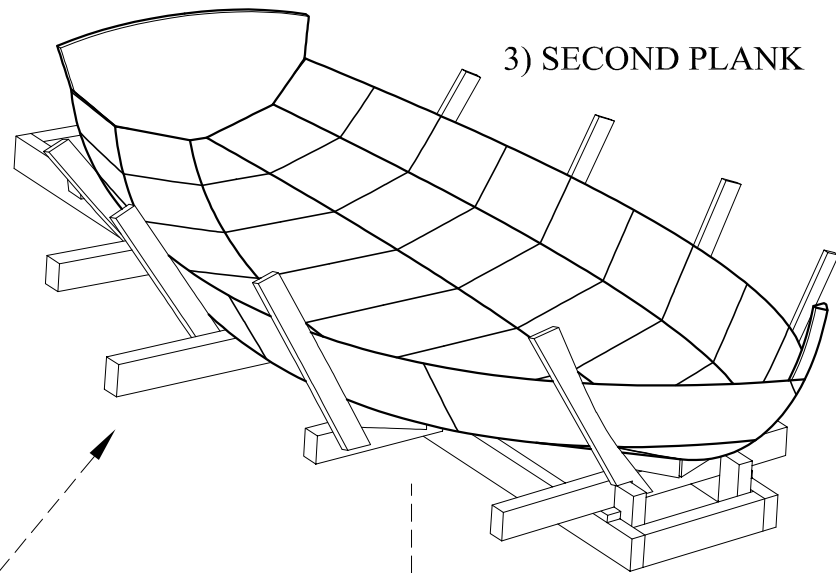

3) SECOND PLANK

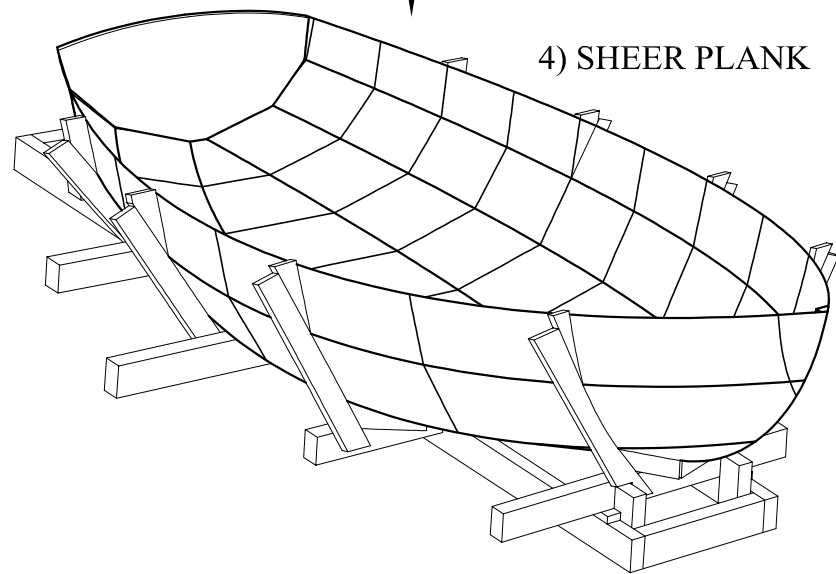

4) SHEER PLANK